

GENERAL REQUIREMENTS HENRY WARRANTED COMMERCIAL ROOFING SYSTEMS

1.0 STATEMENT OF POLICY

The overall performance of a roofing system can be affected by factors other than the roof system installation. Henry Company assumes no responsibility for design of the building, the performance of the substrate over which a Henry Roofing System is installed, or for the performance of products not manufactured and/or sold by Henry Company.

Information and specifications published by Henry Company are intended to provide general assistance to architects, engineers, specifiers, consultants, owners, contractors, and others in the selection of the appropriate Henry Roofing System. Whenever feasible, Henry Company personnel will provide customized specifications and recommendations applicable to each specific roof.

Henry Company reserves the rights to modify, delete from, or add to the contents of specifications and product data without complete republication. Henry shall make its best efforts to provide notice of any modifications to those who have been given this publication by Henry Company. Anyone using these specifications must contact Henry Technical Services at 877-294-4237 to insure that any modifications to these specifications are properly and timely incorporated. Anyone seeking to modify these specifications on a Henry warranted roof system must submit such modifications in writing to Henry Company for approval prior to installation.

The General Recommendations that follow shall be considered a part of each Henry Roofing Specification.

2.0 QUALITY ASSURANCE

2.01 REFERENCES

- A. National Roofing Contractors Association (NRCA) Roofing and Waterproofing Manual and technical recommendations
- B. Western States Roofing Contractors Association (WSRCA) Roofing Details
- C. Midwest Roofing Contractors Association (MRCA) roofing details and recommendations.
- D. American Society of Testing Materials (ASTM)
- E. Sheet Metal & Air Conditioning Contractors National Assoc. (SMACNA)
- F. Underwriters Laboratories (UL)
- G. Factory Mutual (FM)
- H. Metro Dade (Dade County, FL)
- I. Building Officials Council of America (BOCA)
- J. Southern Building Code Congress International (SBCCI)
- K. Steel Deck Institute (SDI)
- L. American Plywood Association (APA)

- M. International Conference of Building Officials (ICBO)
- N. Uniform Building Code (UBC)
- O. SPRI

2.02 PRE-JOB CONFERENCE

- A. Prior to the beginning of work, a pre-job conference shall be held at the job site. Appropriate representatives of the Henry Certified Contractor (HCC), building owner, architect, consultant, subcontractors, and Henry Company shall attend.
- B. During the pre-job conference, attendees shall review the specifications to determine any potential problems, changes, etc. Scheduling, weather conditions, unique job site conditions, installation requirements and procedures and any other information pertinent to the roof system installation shall be discussed.
- C. The results of the conference shall be recorded with copies submitted to all participants.

2.03 APPLICATOR

- A. The roofing contractor must be a Henry Certified Contractor (HCC). Contractor should furnish references for similar projects.
- B. A Henry Certified Contractor must install roofing warranted by Henry Company.

2.04 WARRANTY REQUIREMENTS

- A. Henry Company offers a wide range of warranty options. The warranty is not intended to relieve the owner, architect or contractor of appropriate specifications and contract administration.
- B. To qualify for a Henry warranty, the following requirements must be met:
 - 1. Roofing system must be installed by an authorized Henry Certified Contractor;
 - 2. A Warranty Application must be received and approved prior to job start;
 - 3. A Pre-job Roofing Conference must be held well in advance of project start;
 - 4. Henry Company representatives must have access to the site for in-progress inspections;
 - 5. All punch list items must be completed;
 - 6. Henry Company representatives must complete a final inspection; and
 - 7. All warranty fees must be paid.
- C. To maintain the Henry Company Warranty:
 - 1. Follow maintenance requirements of the warranty;
 - 2. Notify Henry Company when making any changes to the roof and use a Henry Certified Contractor for any tie-in to the roof membrane;
 - 3. In the event of a leak, promptly notify Henry Company.

2.05 ROOF CUTS

- A. Henry Company does not recommend roof core cuts as the standard measurement of quality. Quality materials, specifications and regular inspections are endorsed to provide quality control. Minor deviations (\pm) from recommended application rates may not compromise the performance of the roofing membrane and should be evaluated. When test cuts are required, take not less than 3 random samples and they should be taken as early in the project as practical. Advise the Henry Certified Contractor of any deficiencies on a timely basis for corrective action.
- B. Henry Company will not comment on any test cuts that cannot be shown to be statistically significant and representative of the roofing membrane construction.

2.06 WEATHER CONSIDERATIONS

- A. When ambient temperatures are below 40°F (4°C), rolled materials must be stored in protected or heated areas and brought to the roof as needed for application. When rolls are cut to appropriate lengths, sun warming on the roof may relax the sheets sufficiently to allow installation of the membrane.
- B. Asphalt adhesives and cements shall be stored in a heated area prior to use in cold weather. Solvent-based adhesives and coatings may have to be heated for suitable application by pumping them through specially designed warming equipment.
- C. Never apply solvent-based adhesives or coatings to a wet surface.
- D. Never apply water-based emulsions when the ambient temperature is below 50°F (10°C) or will fall below 40°F (4°C) before the emulsion has cured to a tack-free black surface. High humidity, fog and dew will greatly extend the time for emulsions to dry and cure. To avoid the risk of wash-off, never apply emulsions when rain is predicted before the emulsion can be expected to cure.

2.07 TEMPORARY ROOFS

- A. If weather conditions and project scheduling requires roofing installation before curbs, penetrations or roof top equipment can be installed, a temporary roof should be considered.
- B. If a temporary roof is specified, consult with Henry Company Technical Services to review acceptable procedures.

3.0 STRUCTURAL COMPONENTS

3.01 DECKS - GENERAL

- A. Recommendations contained in the Deck and Structural Design section of the current edition of the NRCA Roofing & Water-proofing Manual are a part of the general recommendations for Henry Roof Systems.
- B. Acceptance of the deck as satisfactory to receive roofing is limited to the condition of the surface to be roofed. The design of the roof deck is the

- responsibility of the Architect, Engineer or Owner.
- C. Deck surfaces are to be clean, firm, smooth, dry and provide unobstructed drainage.
- D. Installation of expansion joints, curbs, outlets, projections and other openings is to be completed before membrane installation.
- E. The structural roof deck over which the Henry roofing system is to be installed must conform to all applicable local or model building codes.

3.02 PLYWOOD DECKS

- A. Follow the deck standards of the American Plywood Association for type, grade, and installation methods for Low Slope roofs. Plywood to conform to PS-1-83. Panels must meet or exceed a span rating of 32/16 and be a minimum of 15/32 inch (12mm) thick.
- B. Plywood panels are to be installed at right angles to rafters, continuous over two (2) or more spans with either solid backing or panel clips stiffening all joints between rafters. Rafter spacing to be 24 inch (610mm) maximum.
- C. Mechanically fasten underlayment with annular threaded ring, barbed-shank nails or by approved pneumatically driven fasteners. **Do not apply adhesive directly to plywood.** Install dry sheathing paper over roof area.

3.03 ORIENTED STRAND BOARD (O.S.B.)

- A. Henry Company must pre-approve installation of Henry's Roof System over OSB decks.

3.04 WOOD PLANK DECKS

- A. Wood plank decks are to be nominal 1 inch (25mm) or thicker and of tongue-and-groove, shiplap or butt joint construction. Cover cracks and joints greater than 1/2" (13 mm) in diameter with sheet metal nailed in place. Install dry sheathing paper over the entire roof area.

3.05 STEEL DECKS

- A. Steel decks are to be 22 gauge or heavier and factory galvanized in compliance with ASTM A-525, Class G-60 or G-90. Install deck in accordance with recommendations of the steel deck manufacturer, Steel Deck Institute, Factory Mutual structural requirements and Factory Mutual Loss Prevention Data Sheet 1-28. Steel decks are to be clean and dry. Top flanges are to be flat.

3.06 Poured Structural Concrete Decks

- A. The roof deck shall be thoroughly cured, smooth, clean, dry, and adequately sloped to outlets. Non-insulated roof assemblies require installation of base sheet in spot application of Henry #902 Permanent Bond Adhesive or #903 High Solids Adhesive as described in these specifications.

3.07 PRECAST CONCRETE & GYPSUM DECKS

- A. Secure fastening of deck units to the structure is mandatory to prevent lateral and vertical movement. Joints must be properly caulked or grouted. Level any irregularities in deck with suitable fill material.

- B. When installing a non-insulated roof system, apply the underlayment or base sheet by spot application of Henry #902 Permanent Bond Adhesive or #903 High Solids Adhesive. Adhesive to be 9" (229mm) diameter applied 18" (457mm) o.c., staggered in two rows 12" (305mm) from each edge. Contact Henry Technical Services for mechanical attachment of base sheet recommendations.
- C. Over pre-stressed T or TT sections, roof insulation shall be installed as a leveling course in accordance with Factory Mutual and the insulation manufacturer's requirements.

3.08 NEW LIGHT WEIGHT INSULATING CONCRETE

- A. Underside venting and perimeter venting are recommended for aggregate lightweight insulating concrete.
- B. Before applying a roofing system to this deck, the HCC must furnish Henry Company with a letter of certification from the deck manufacturer and its installer. Letter must clearly state that the deck conforms to that manufacturer's requirements, results of pull tests (minimum 3 per roof) and that the deck is ready for the roof membrane application.
- C. Install the specified Henry base sheet over the approved lightweight deck. Use fasteners approved by Factory Mutual for wind uplift requirement. Follow Factory Mutual fastening pattern criteria for specified wind uplift.
- D. On decks with no underside venting install 4" (102mm) minimum diameter vapor release vent. Install one vent unit for each 1600 sq. ft. (148.6m²) of roof area. Space units 40 feet (12m) apart and not more than 20 feet (6m) from perimeter, directly over 4" (102mm) diameter opening cut through the roof membrane, insulation and insulating concrete, to the structural deck surface. Flash unit in accordance with vapor release vent manufacturer's details and recommendations.

3.09 EXPANSION JOINTS

- A. Provisions for expansion joints are the responsibility of the building designer. Henry Company endorses the following industry recommendations on where expansion joints are provided in the structural system:
 1. At all places where the structural supports and roof assembly change direction.
 2. Where type of adjoining deck materials change.
 3. At intersections between new and old buildings.
 4. At junctions where interior temperature conditions change.
 5. On areas larger than 200 continuous feet (61m) in any direction.
 6. Where movement may occur between vertical walls and the roof deck.

3.10 STRUCTURAL WOOD FIBER ROOF DECKS

- A. Structural wood fiber decks incorporating composite elements such as chipboard, particle

board, polyurethane insulations, etc. are not approved substrates for Henry Roof Systems. Henry Company will not issue its Warranty over these deck types (contact Henry Company technical department for further information).

- B. New construction requirements for structural wood fiber decks:
 1. Henry #607 Fiberglass Ply Sheet, *modified*PLUS G100s/s or *modified*PLUS NP180s/s base sheet must be mechanically fastened, followed by a min. 3/4" rigid insulation board (applied at a right angle to the panel length). Insulation must be applied to the base sheet using Henry #111 InsulBond Insulation Adhesive.
 2. A minimum 4 ply Henry Gravel Surfaced roofing system must be installed.
- C. Recovering requirements for structural wood fiber decks:
 1. The existing roof system must be suitable and acceptable for application of a new roof system and must receive prior approval from Henry Company to qualify for a Henry Warranty System. Moisture laden or badly deteriorated existing roof systems are not acceptable.
 2. A minimum 1/8" layer of Henry Re-Cover Board must be installed in accordance with Henry Company specifications.
 3. In the case of re-roof with complete tear-off, because of the potential for damage to the deck system and structural integrity of the deck during membrane removal, the Henry Company will not be responsible for damage to the deck.

3.11 CURBS

- A. Curbs shall be minimum 8" (204mm) above the completed roof assembly unless otherwise approved by Henry Company. Properly secure curbs to the structural deck. Prefabricated curbs are to be faced with insulation or plywood. Prefabricated metalcants are not acceptable.

3.12 WOOD NAILING STRIPS

- A. Pressure treated wood nailing strips are required at eaves, perimeter edges, roof openings, etc. for proper securement of metal flashings. Width of nailing strips shall be a minimum of 4" (102mm), or 2" (51mm) wider than the flange of metal edging. Thickness shall be the same as roof insulation and/or the tapered edge strips, whichever is greater. Nailers must be securely and firmly attached to the deck.
 1. Comply with Factory Mutual Loss Prevention Data Sheet 1-49 Wood Nailer design.
 2. Where insulation is used and for all non-nailable decks specify wood nailers so upper surface is flush with the surface to which the roofing membrane is to be applied and are a minimum 2 inches (51mm) wide.

- B. Wood nailers are required on all prefabricated curbs and hatches for attachment of membrane base flashings.

4.0 **SLOPE & DRAINAGE**

4.01 **GENERAL**

- A. The roof deck/roof substrate must be designed to result in positive drainage of free water from the roof surface to interior or perimeter drainage systems of sufficient capacity to remove water from all roof surfaces within 48 hours of precipitation.
- B. The NRCA minimum recommendation for roof slope is 1/4" per foot; it is the responsibility of the building owner's building designer to ensure adequate slope for positive drainage in the particular building design.
- C. Drainage may be facilitated by sloping the structural deck, inclusion of tapered roof insulation, crickets/saddles, or by adding additional roof drains.
- D. In re-covering situations, Henry #176 PondPatch™ may be used in low areas of the existing substrate to help promote proper drainage. Roof vent(s) are required if the area is to be covered with a non-breathing membrane.
- E. Unless these drainage parameters are met, Henry warranties exclude areas of ponding water from warranty coverage.

4.02 **INTERIOR DRAINS**

- A. Recess interior roof drains below the level of the finished membrane to allow positive drainage.
- B. Provide drains with corrosion resistant strainers.

4.03 **SCUPPERS**

- A. Provide scuppers with minimum 4" (102mm) wide flanges on all sides to be worked into the layers of roofing.

4.04 **OVERFLOWS**

- A. Install overflows 2-4" (51-102mm) above every outlet, above the roof level and below the counter flashing, or as required by local code requirements. Size must also be in accordance with local code requirements.

4.05 **VALLEYS**

- A. Reinforce all valleys with an extra layer of the specified Henry ply sheet and adhesive. Extend ply at least 12" (305mm) up inclines. Apply in the direction of the slope of the valley, lapping 4" (102mm) on ends.

4.06 **CURBS & PENETRATIONS**

- A. Install crickets on the high side of curbs.
- B. Avoid installing curbs and penetrations in waterways that will interfere with drainage.

4.07 **STEEP SLOPE**

- A. On slopes greater than 1½" per foot (125mm/m), back nail interply sheets 2" (51mm) from top edge, 12" (305mm) on center.

- B. On slopes over 3" per foot (250mm/m), install interplies parallel to slope blind-nailing 4" (102mm) end laps only, 6" (152mm) on center.

5.0 **ROOF ASSEMBLY COMPONENTS**

5.01 **GENERAL**

- A. Roof membrane, membrane flashings, adhesives, mastics and coatings shall be manufactured or supplied by Henry Company and bear the Henry Company label.

5.02 **BASE SHEET/UNDERLAYMENT**

- A. Base sheet plies and underlayments must be cut to 18' lengths. Allow material to flatten.
- B. **STANDARD FASTENING (PLYWOOD)-**
 1. Nail base sheet/underlayment at side laps 9" (229mm) on center and in two staggered rows 18" (457mm) on center, 12" (305mm) from each edge.
 2. For installations in high wind regions, contact Henry Company Technical Services for fastening pattern recommendations.
- C. **FASTENING (LIGHTWEIGHT INSULATING CONCRETE) –**
 1. Nail base sheet/underlayment at side laps 7" (178mm) on center and in two staggered rows 7" (178mm) on center, 12" (305mm) from each edge.
 2. When following Factory Mutual criteria for 1-60 on installations with parapet walls less than 3 ft. (0.9m) increase fastening in corners by 50%.
 3. For FM 1-90 and installation with parapet walls less than 3 ft. (0.9m) increase fastening at perimeter by 50% and corners by 100%.
 4. For FM 1-90 installations with parapet walls greater than 3 ft. (0.9m) increase fastening at perimeters and corners by 50%.
- D. **NON-NAILABLE DECKS –**
 1. **WITH INSULATION – BASE SHEET ALTERNATE.** Fully adhere a base sheet in the specified adhesive with 2 inch (51mm) side laps and 4 inch (102mm) end laps may be used as a substitute for the first ply.
 2. **WITHOUT INSULATION.** Adhere ply with 9" (229mm) diameter spot application of Henry #902 Permanent Bond Adhesive or #903 High Solids Adhesive 18" on center, staggered in two rows 12" (305mm) from each edge.

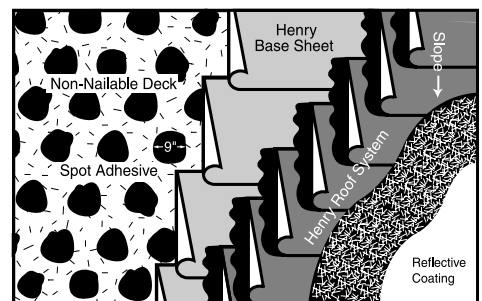

BASE SHEET ATTACHMENT- NON-NAILABLE DECKS

5.03 VAPOR RETARDERS

- A. The necessity for and selection of a vapor retarder in the roofing assembly is the responsibility of the owner's building designer. Henry Company assumes no responsibility for determining whether a vapor retarder is to be included in the roofing assembly, for the performance of any vapor retarder specified, or for damage to the Henry Roofing System caused by failure to include an effective vapor retarder in the roofing assembly.

5.04 INSULATION

- A. Roof insulation materials used in Henry Roofing Systems must be specifically manufactured for use as roof insulation, be listed and approved by Underwriters Laboratory and Factory Mutual, and approved by Henry Company.
- B. It is recommended and desirable that roof insulation in all roofing assemblies be installed in two layers. Offset the joints in each layer 6" (152mm) minimum so that there is no continuous vertical joint through the multiple insulation layers.
- C. When mechanically attaching insulations, refer to the FMRC (Factory Mutual Research Corp.) Approval Guide and/or Henry Company Technical Dept., as well as the insulation manufacturer and NRCA recommendations for fastening requirements.
- D. Apply insulation flush to all vertical surfaces and wood nailers. Butt insulation joints. Fill gaps with additional insulation. Replace boards that are damaged. Taper insulation to all drains.
- E. All insulation must be covered with a finished roofing membrane by end of each day's work.
- F. Do not use solvent-containing adhesives anywhere in a roof assembly when polystyrene (EPS) or other solvent-sensitive insulation is used. Henry #111 InsulBond Insulation Adhesive and Henry #107 Asphalt Emulsion interply adhesive with polyester fabric plies, or Henry #902 Permanent Bond Adhesive or #903 High Solids Adhesive with *modified*PLUS™ or Henry #604 or #607 Fiberglass Ply Sheets are the recommended systems.
- G. 4' x 4' is the maximum allowable size when insulation or *Densdeck*™ is installed in cold adhesive or hot mopped (4' x 5' maximum for Henry Re-cover Board).
- H. Following are minimum requirements:
 - 1. **POLYISOCYANURATE** – Federal Specification FS HH-1-1972/GEN and HH-1-1972/2 Class 1. ASTM C-1289-95, Type II
 - a. Density – ASTM D1622 (nominal 2 pcf)
 - b. Compressive Strength – ASTM D1621 – nominal 20 psi
 - c. **An overlay of perlite, fiberboard fiberglass or Henry Re-Cover Board is required.**

- 2. **WOOD FIBERBOARD** – ASTM C-208, Fed.Spec. LLL-1-5356
 - a. Regular Density - Compressive Strength – ASTM C165 (nominal 30 psi)
 - b. High Density - Compressive Strength – ASTM C165 (nominal 45 psi)
- 3. **PERLITE** – ASTM C728, Fed. Spec. HH-1-529
 - a. Compressive Strength – ASTM D1621 32 psi
- 4. **FIBERGLASS** – ASTM C 726, Fed. Spec. HH-1-526; CGSB 51.020M, Type II, Type IV
 - a. Compressive Strength – ASTM D1621 12 psi
- 5. **EXPANDED POLYSTYRENE** – ASTM C – 578-85– Type IV
 - a. Density – 1.5pcf
 - b. Compressive Strength – ASTM – D1621 – 15-21
 - c. **An overlay of a minimum ½" perlite, fiberboard or Henry Re-cover Board is required.**
 - d. **Use of EPS under solvent base systems requires prior approval of Henry Technical Services.**
- 6. **EXTRUDED POLYSTYRENE** – ASTM C – 578-92– Type VI
 - a. Compressive Strength – ASTM – D1621 – 40 psi
 - b. **An overlay of a minimum ½" perlite, fiberboard or Henry Re-cover Board is required.**
 - c. **Use of EPS under solvent base systems requires prior approval of Henry Technical Services.**
- 7. **COMPOSITE INSULATION** – Polyisocyanurate with perlite laminated to surface - ASTM C-984
 - a. Density – ASTM D1622 (nominal 2 pcf)
 - a. Compressive Strength – ASTM D1621
- 8. **TAPERED INSULATION**
 - a. Perlite, Fiberboard, Fiberglass and Expanded Polystyrene are acceptable materials.
 - b. Consult with Henry Technical Services for approval when combined thickness is over 6 inches (153mm).
- 9. **FOAMGLAS® ROOF INSULATION**
 - a. (Flat or tapered) manufactured by
 - b. Pittsburgh Corning conforming to ASTM – C552 maximum size 4' x 4'.
- 10. **DENSDECK™**
 - a. Densdeck™ board as manufactured by Georgia Pacific Corp., maximum 4'x8' size.

InsulBond™ Application Method Reference Chart

	Perlite	Fiberboard	Composite	Densdeck	Fiber-glass	FoamGlass	Henry Re-cover Board	ISO	EPS	XEPS	Base Sheet	Concrete(1)	Steel(2)	Wood	Lt. Wt. Insulating Concrete
TYPE A - WET APPLICATION; TYPE B - CONTACT APPLICATION															
Perlite	A or B	A or B		A or B	N/A	A or B	A or B	A or B	A or B	A or B	A or B	A	A	A or B	A
Fiberboard	A or B	A or B		A or B	N/A	A or B	A or B	A or B	A or B	A or B	A or B	A	A	A or B	A
Composite	Follow Guidelines for ISO and/or Perlite as applicable to surface to be adhered with Insulbond														
Densdeck	A or B	A or B		B	N/A	B	B	B	B	B	B	A	A	A or B	A
EPS	A or B	A or B		B	N/A	B	B	B	B	B	B	A	A	A or B	A
Fiberglass	Not Applicable														
FoamGlass	A or B			B	N/A	B	B	B	B	B	B	A	A	A or B	A
Henry Re-cover Board	A or B	A or B		B	N/A	B	B	B	B	B	B	A	A	A or B	A
ISO	A or B	A or B		B	N/A	B	B	B	B	B	B	A	A	A or B	A
XEPS	A or B	A or B		B	N/A	B	B	B	B	B	B	A	A	A or B	A
Base Sheet	A or B	A or B		B	N/A	B	B	B	B	B	N/A	N/A	N/A	N/A	N/A
Concrete(1)	A	A		A	N/A	A	A	A	A	A	A	N/A	N/A	N/A	N/A
Steel(2)	A	A		A	N/A	A	A	A	A	A	A	N/A	N/A	N/A	N/A
Wood	A or B	A or B		A or B	N/A	A or B	A or B	A or B	A or B	A or B	A or B	N/A	N/A	N/A	N/A
Lt. Wt. Insulating Concrete	A	A		A	N/A	A	A	A	A	A	A	N/A	N/A	N/A	N/A
(1) If deck was previously primed follow Type B - CONTACT APPLICATION - Deck surface must be smooth.															
(2) Fluted Steel Decks															
TYPE A - WET APPLICATION; TYPE B - CONTACT APPLICATION															

5.05 INSULATION ATTACHMENT

Refer also to the InsulBond Application Method Selection Chart.

A. MECHANICAL ATTACHMENT

1. Consult the Factory Mutual Approval Guide and the insulation manufacturer for recommended fastening pattern and approved fasteners and plates.
2. Henry Company requires not less than 1 fastener per 2.7 sq. ft. (.25m²) with a fastener in each corner.
3. All insulation must be installed with the joints of successive rows staggered by at least 6" from each other.

B. #111 INSULBOND INSULATION ADHESIVE

1. **SURFACE PREPARATION** – Surface must be clean and dry and free of dust, dirt, grease, oil and other foreign material. If necessary, steel decks may be cleaned with white vinegar or TSP solution (1-1/2 lbs:5 gallons water). Rinse thoroughly and allow to dry. Rust and scale must be removed from metal surfaces by wire brushing. Surfaces must also be free from foreign matter such as grease, water repellants, or curing agents which might interfere with a good bond.
2. **PROTECT FROM FREEZING:** Do not apply InsulBond #111 Insulation Adhesive if temperatures are 40°F or below or if

temperatures are expected to fall below 40°F before adhesive is cured. For best results, store adhesive at 70°F prior to application.

3. InsulBond Application Methods (Refer to InsulBond Application Method Reference Chart for appropriate usage)

a. **WET APPLICATION METHOD:** Apply #111 InsulBond Insulation Adhesive at a rate of 2 to 2-1/2 gallons/100 sq. ft. (.8-1.0l/m²). Install material in a serpentine or parallel pattern 6" (153mm) apart. Stripes of 1/2" (13mm) diameter or 1-1/4" (32mm) wide by 3/16" (5mm) thick will provide the proper quantity (one per flange on steel decks). Use a pour can or heavy duty wand. Set insulation into the #111 InsulBond Insulation Adhesive. Allow no more than 10-20 minutes of air exposure prior to setting the insulation into the wet adhesive and walking it in.

b. CONTACT APPLICATION METHOD

1. Apply InsulBond #111 Insulation Adhesive at a rate of 1 to 1-1/4 gallons/100ft² (.4-.5 l/m²) to **each** of the two surfaces to be joined, using trowel, brush, roller or heavy duty spray equipment.

2. Let adhesive dry to the touch. Allow 20 minutes to 3 hours drying time depending on temperature and humidity.
3. Carefully position the insulation board above the previous layer. Set in place and walk it in. Bonding occurs instantly, therefore careful positioning is critical.

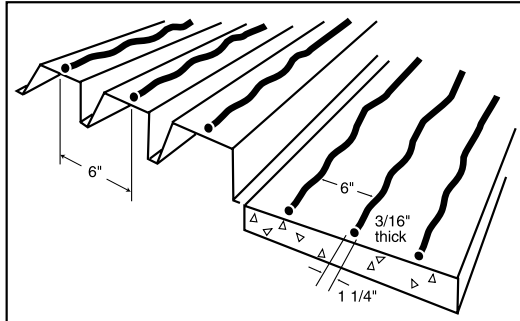

InsulBond

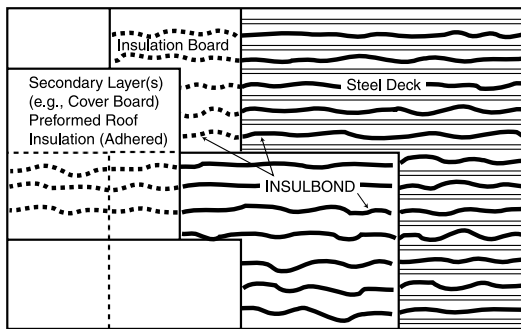

5.06 MISCELLANEOUS MATERIALS

A. FASTENERS

1. Only use corrosion resistant screws, plates and nails. Base sheet fasteners over plywood must have minimum one inch head. Follow fastening pattern and minimum plate sizes outlined per fastener manufacturer specifications. Comply with local building codes or FM approved fasteners when specified.

B. SHEET METAL

1. Sheet metal is to be a minimum of 24 gauge galvanized steel.
2. Apply Henry #103 or #104 asphalt primer to all surfaces of sheet metal that will come in contact with roofing mastics, adhesives and coatings.
3. Solder all joints. Corner flanges must be full corners.
4. Provide metal clips one gauge heavier than coping, gravel stop or edge metal.
5. Face of counterflashing and gravel stop or edge metal should be sufficient dimension to cover top of flashing or wood blocking. If necessary add sheet metal "skirt".

C. WALK PADS

1. Walk pads should be a minimum 32"(813m) x 32"(813m) x 3/8"(10mm) and specifically manufactured for intended use.
2. Install walk pads over finished roof. Space pads 2" (51mm) apart to allow drainage.
3. Set walk pads in not less than 5 generous spot applications of the specified mastic.
4. Walk pads are required where roof is accessed and on service side of equipment.

D. GRANULES -

1. #11 Ceramic Granules

E. GRAVEL

1. ASTM D-1863 - Gravel must be clean and dry.

F. CANT STRIPS

1. Cant strips are required at all roof horizontal to vertical transitions. Cant strips: ASTM C-208, preformed fiberboard, 3" (76mm) height typical.

G. PIPE PENETRATIONS, ELECTRICAL JACKS, EQUIPMENT STANDS AND PITCH POCKETS

1. Pitch pockets are a maintenance item and should be eliminated. Wherever possible install round penetrations to facilitate use of lead flashings.
2. Install storm collars on all pipe penetrations and jacks.
3. PITCH POCKETS – When pitch pockets are required, furnish pans a minimum 2-1/2" (65mm) deep with a minimum 4" (102mm) flange. Install the pans on the finished membrane with the flange set in Henry #504 Plastic Roof Cement and nailed 3" (76mm) o.c. Strip in flange with two layers of specified ply sheets set in Henry #504 Plastic Roof Cement. Extend plies 4" (102mm) and 6" (152mm) onto roof surface. Fill base of pitch pan with non-shrinking grout or #176 Henry PondPatch™ to within 1 1/2" to 2" (39mm-52mm) of top of pitch pan and top with Henry #504 Plastic Cement. Slope to facilitate drainage away from the penetration. Approved 2-part neoprene elastomeric sealant may be used in lieu of Henry #504 Plastic Cement with prior approval from the Henry Technical Department.

6.0 REROOFING

6.01 GENERAL RECOMMENDATIONS

- A. The decision to tear off and replace ("reroof"), or recover (install a new roof over an acceptable existing roof) is the responsibility of the building owner, specifier, or contractor, and must be made with due consideration to local code requirements.
- B. Tear off and replacement is mandatory if the existing roof system is badly deteriorated, if the roof has been recovered one or more times, if the existing roofing is not securely attached to the

deck, if the underlying insulation has become wet, or if the roof decking has deteriorated.

- C. Consult with Henry Company technical department regarding warranty availability for Re-cover specifications.
- D. Consult with Henry Company representative in your area to determine if the roof is an appropriate candidate for a Henry Restoration Program or requires reroofing or re-covering.

6.02 RESTORATION OF EXISTING ROOFS

- A. See Roof Maintenance & Restoration Systems.

7.0 RE-COVERING OF EXISTING ROOFS

- A. If a recover application is anticipated Henry Company strongly recommends and may require that either a nuclear or infrared nondestructive evaluation (NDE) be performed for all roofs which are to be applied over existing roof systems.
- B. As an alternative, at Henry Company's discretion, a submittal from the Roofing Contractor may be acceptable confirming that core cuts, consisting of at least 4"x4" roof cuts or cylindrical plugs of all existing roofing materials down to the actual surface of the structural deck have been taken no less than one every twenty squares (2,000 sq. ft.) in the existing roof assembly to confirm the existing roof system is dry and free of trapped moisture. Officer of the Roofing Contractor must provide written affirmation that such cuts have been performed and that either:
 - 1. these cuts have confirmed that the existing roof assembly is dry, i.e., that all materials still retain structural integrity and show no obvious evidence of moisture, or
 - 2. all wet roofing materials found by such method are entirely removed and replaced prior to installing the recover roof system.
- C. Contractor shall be responsible for:
 - 1. Removal of all existing membrane curb and wall flashings and existing penetration membrane, metal and lead flashings and replacement with new.
 - 2. attachment of all existing roofing system(s) to nailable decking, and, if the old roof is not properly attached, installation of new mechanical fasteners down through the existing roof(s) and incorporated insulation, solidly into the existing deck.
 - 3. compliance with all building codes relating to number of existing roofs allowed without mandating their removal and all regulations relating to permissible live and dead loading of roof deck structures which may be applicable to roofs incorporating Henry Company's materials.
- D. Existing Roof Preparation and Requirements
 - 1. The same existing roof preparations and guidelines apply in recover applications.

Once suitability for recovering has been determined, existing roofs must be clean, dry, and properly prepared. Refer to the entire *General Requirements for Roof Maintenance & Restoration Systems section with respect to surface preparation prior to recovering an existing roof with a new Henry Roof System.*

- 2. A minimum 1/8" layer of Henry Re-Cover Board must be installed in accordance with Henry Company specifications over spudded, swept existing gravel roofs prior to application of Henry *modified*PLUS cold process specifications, Henry Roof Systems, and in any situation where recovery board is necessary to achieve a smooth, uniform surface prior to application of the new roof system.

8.0 SPECIAL CONSTRUCTION

Cold storage, freezers, buildings containing high humidity, high interior temperatures, roofs with window washing equipment or heavy foot traffic may require special specifications. Consult with the Henry Company technical department for suitability of a particular specification.

9.0 SAFETY PRECAUTIONS

- A. Flammable materials should not be stored near building exits. "No Smoking" signs must be posted and clearly visible where this material is stored.
- B. Do not expose cold adhesives to open flame or heat. Do not heat container or store at temperatures above 120°F.
- C. When using solvent based products, close all air intakes on roof until solvents dissipate. Avoid breathing of vapors. Use only with adequate ventilation.
- D. Follow all safety, application and technical guidelines listed on the individual Henry product Data Sheets found in the Henry Roofing Systems technical binder.

10.0 HANDLING & STORAGE

- A. Follow all safety and application precautions listed on product labels.
- B. Protect from freezing
- C. Close all containers after use.
- D. Do not mix water-based products with solvents or solvent based products.
- E. Do not dilute roof coatings, mastics or adhesives. Asphalt emulsion can only be diluted when used as a primer prior to emulsion coating application as specified in this manual (see Specifications).