

LEISTER

Plastic Fabrication with LEISTER



Basic Welding Principles

Materials in Plastic Fabrication

	Scope (°C)	Behaviour in fire	Chemical resistance	Remarks
HDPE	-50 °C to +90 °C	yellow flame, blue core, paraffin-like smell	resistant to acids, leaches and alcohols	sanitation tubes, tank construction, ski coatings, toys
PP	0 °C to 110 °C	yellow flame, blue core, paraffin-like smell	very good when in contact with weak acids, leaches and solvents	benches, ventilating tubes, tank construction
PVDF	-60 °C to +150 °C	self-extinguishing, flame resistant, sharp smell	Outstanding when in contact with halogens and hydrocarbons	chemical facilities, clean room applications (pay attention to the safety regulations!!)
PVC-U	up to 65 °C	extinguishes when removing from the flame	high chemical resistance	chemical plant construction
PVC-C	up to 130 °C	inflammable	high chemical resistance at high temperature	chemical plant construction at increased temperature
PVC-P	up to 65 °C	flammable depending on portion of softener smells of HCl	chemical resistance depends on portion of softener	hoses, gaskets, coatings
PMMA (Acryl)	up to 85 °C	crackling burning, smoking and smells of fruits	resistant to weak acids and leaches and aliphatics	takes in a lot of humidity > blowholes is often clued

Basic Welding Principles

Welding Procedure

With Leister

- Pendulum Welding (PW)
- Draw Welding (DW)
- Hot Air Extrusion Welding (EW)

Other Welding Procedures

- Heating element butt welding
- Heating element groove welding
- Heating element bend welding
- Heating element socket welding
- Heating element helix welding



Basic Welding Principles

Choice of Welding Procedure

Pendulum Welding (PW)



- for confined spaces
- for short seams and repair work
- for wall thickness of up to 5-10mm

Draw Welding (DW)



- DW is faster than PW
- PVC-U cannot be welded with DW (wire tears)
- for wall thickness of up to 10mm

Hot Air Extrusion Welding (EW)



- better seam quality than with PW/DW
- more economic than DW/PW as much faster
- for wall thickness of up to 40mm

Summary Theory

- Introduction Plastic Fabrication
- Basic Welding Principles
- **Pendulum Welding and Draw Welding**
- Hot Air Extrusion Welding
- Arrangement of Welding Constructions
- Test of Welding Connections

Pendulum Welding (PW)

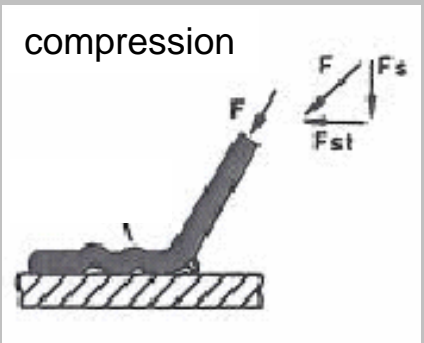
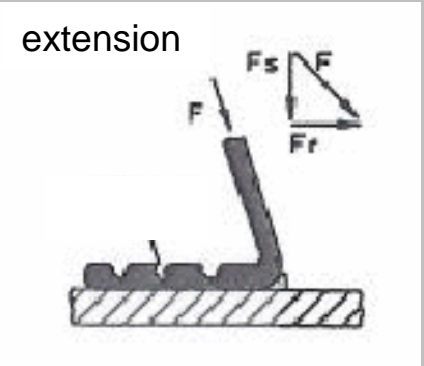
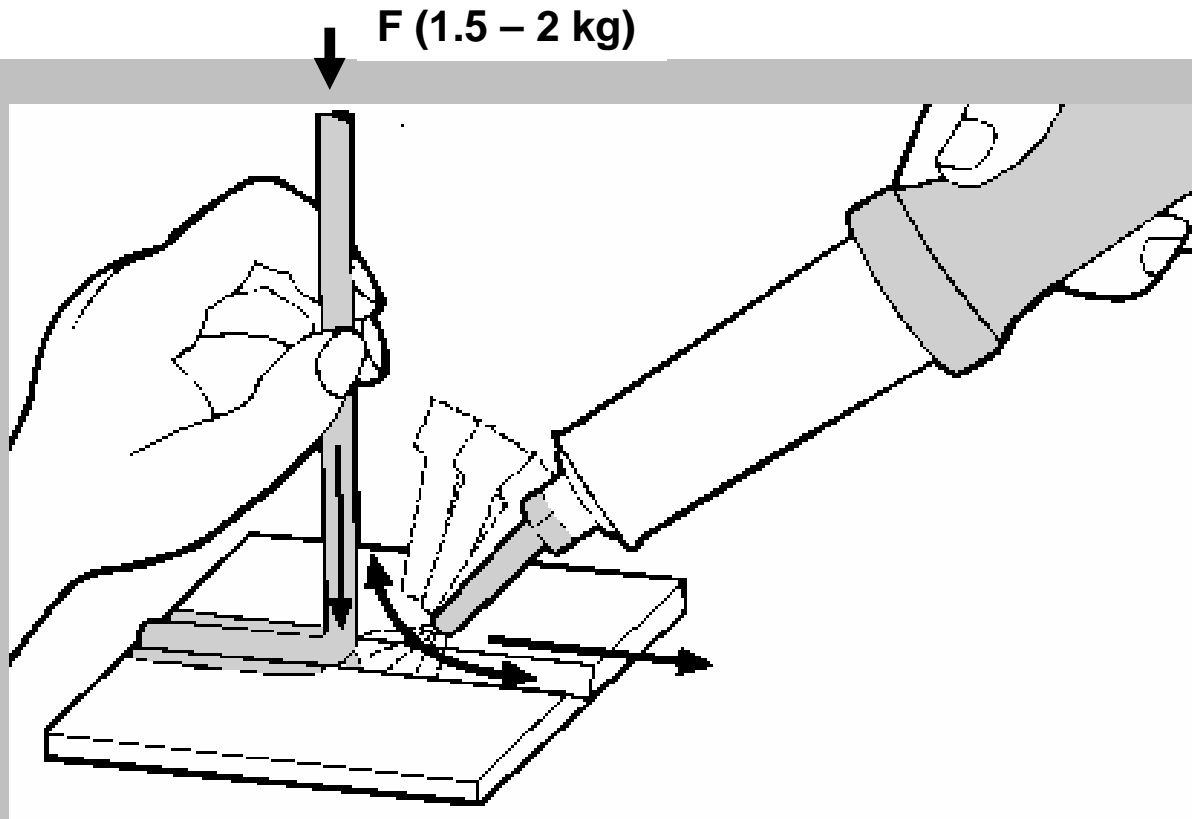

The welder has to pay attention to the following:

- **even** heating up of basic and additional material
- **vertical** guidance of the additional bar
- sufficient **welding force**

Draw Welding (DW)

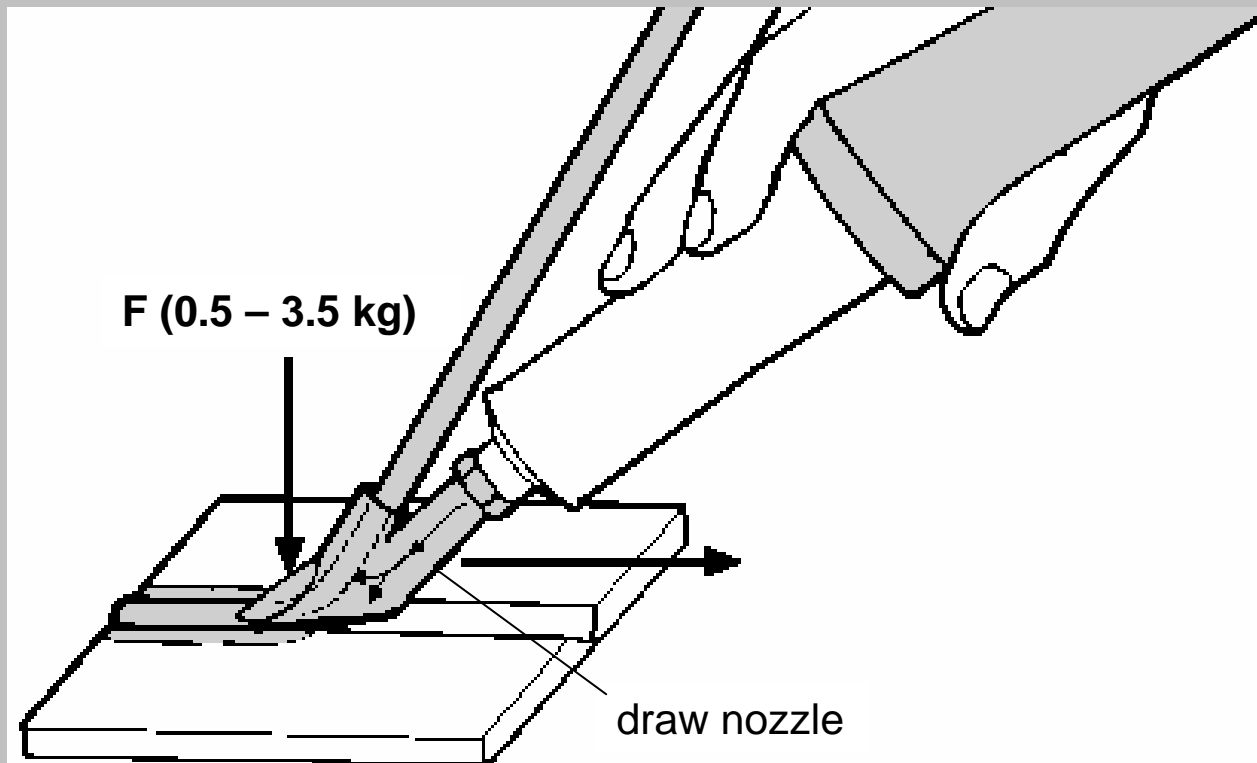

Advantages over pendulum welding:

- **higher** welding speed
- **bigger cross sections** of the welding addition possible (profile welding rod)

Draw Welding (DW)



WELDING PEN R



TRIAC PID

Hot Air Welding

Welding Parameters (according to DVS 2207 part 3)

Material	Welding procedures	Welding force F (N) 3mm	Welding force F (N) 4mm	Hot air temp. (°C)	Airflow l / min
PE-HD	PW	6 – 10	15 – 20	300 – 320	40 – 50
	DW	10 – 16	25 – 35		
PP	PW	6 – 10	15 – 20	305 – 315	40 – 50
	DW	10 – 16	25 – 35		
PVC-U	PW	5 – 9	8 – 12	330 – 350	40 – 50
	DW	8 – 12	15 – 25		
PVC-C	PW	10 – 15	15 – 20	340 – 360	40 – 50
	DW	15 – 20	20 – 25		
PVC-P	PW	15 – 20	18 – 25	300 – 370	40 – 50
	DW	4 – 8	7 – 12		
PMMA	PW	12 – 16	12 – 16	320 – 370	40 – 60
	DW	12 – 16	20 – 30		
PVDF	PW	10 – 15	15 – 20	365 – 385	45 – 55
	DW	12 – 17	25 – 35		

PW = Pendulum Welding
DW = Draw Welding

The hot air temperature is measured in the hot air stream, approx. 5mm in the middle of the nozzle.

Hot Air Welding

Welding Seam Preparation

Welding area and welding rod:

- dry, clean, free of oil and grease
- free of splints
- free of notches
- free of oxidation
(joining area has to be scraped off right before the welding process)

Air pressure:

- The use of air pressure requires the installation of pressure reducer with oil and water separator.

Hot Air Welding

Welding Seam Shapes (DVS data sheet 2207 part 3, 2205 part 3 and 5)

V-Seam

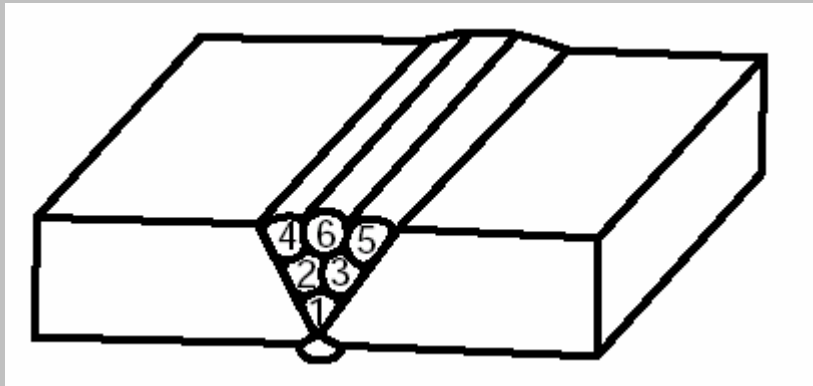

X-Seam (double-V-seam)

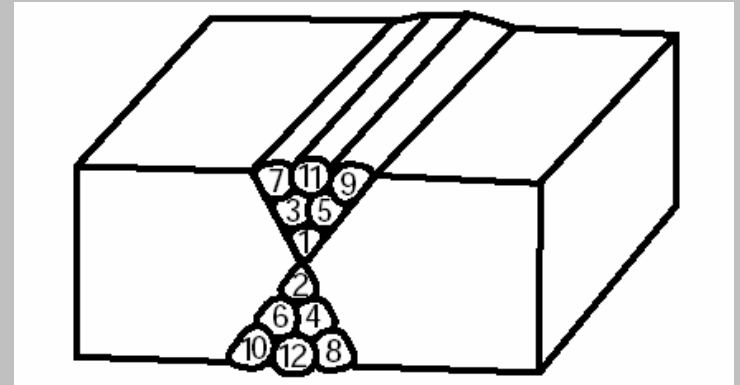

X-seam for thickness of 5mm and more

Angle Joints

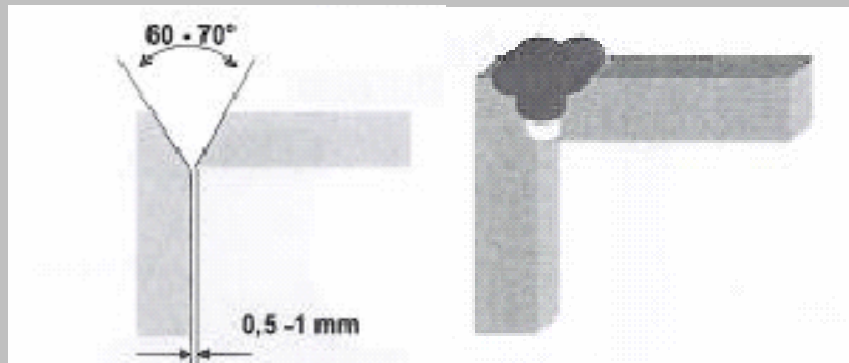

Fillet weld

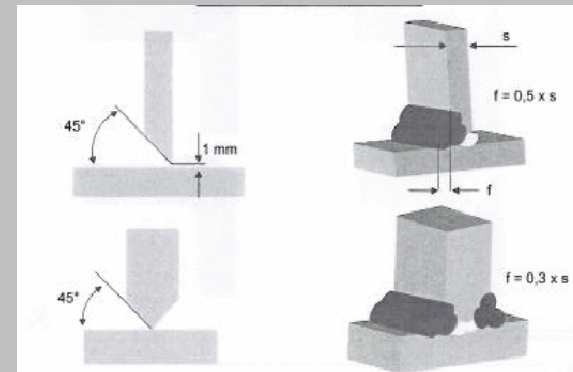

Hot Air Welding

Evaluation of the Welding Seams

Correctly welded seams:

- slight flattening of the welding rod
- no notches between the welding layers
- flat seam raise
- in particular for PVC:
 - foamy to smooth bead
 - no discolouring (e.g. brownish colour)
- in particular for PE, PP, PVDF:
 - smooth double bead on both sides
 - dull surface in the area of the welding zone

Hot Air Welding

Evaluation of the Welding Seams

Flawed welding seams:

- no building of bead or welding rod hardly flattened
 - >> *temperature too low or*
 - >> *speed too fast or*
 - >> *welding force too small*
- notches between the welding layers
 - >> *distance between the layers too big*

Hot Air Welding

Evaluation of the Welding Seams

Flawed welding seams:

- in particular for PVC:
brownish discolouring of the
welding bead
>> *temperature too high or
speed too slow*
- in particular for PE, PP, PVDF:
shiny welding zone
>> *temperature too high or
speed too slow*

Hot Air Welding Tools

Built in air supply



External air supply with air pressure or Robust



Blower:



External air supply with blower or pressure air



Blower:

