

SPECIALTY ROOF VENTS

UNIVERSAL PITCH SOL-A-VENT®

FOR EFFICIENT VENTING OF FLAT OR PITCHED ROOF SYSTEMS

Designed for both residential and commercial applications, the Universal Pitch Sol-A-Vent® provides for continuous venting of open spaces and roof systems. Made of aluminum with riveted seam construction, Sol-A-Vent® is easily installed to prevent winter ice build-up and provide on-going energy savings by improved venting. This unit may be installed on roofs to a 12/12 pitch.

Powered by the sun, the 4" solar cell generates power performing effectively during overcast days, in shade and during low light periods of early dawn and late dusk. **An internal rechargeable Nicad battery will provide continuous power when no solar power is present.** This unit will operate quietly and requires no external power source, wiring or switches and may be painted to match the colors of shingles or other roof membranes.

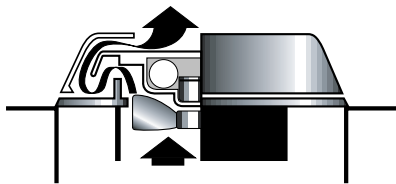

Efficient baffle system allows air to exhaust but keeps rain and snow from entering.

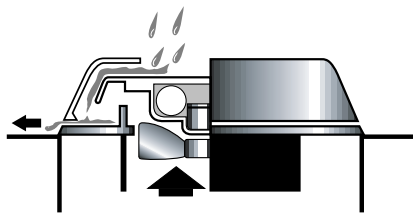

FEATURES:

- Positive venting—rain or shine for flat or pitched roofs.
- Continuous, non-stop exhaust flow—day or night!
- Powered by nature
- Hyper-sensitive solar cell provides earlier, longer ventilation
- Sol-A-Vent's superior design maximizes air flow, seals out water
- Trouble-free installation and durable materials let you rest easy...

A more sensitive solar cell starts working earlier. The powerful, 4" diameter solar cell generates power at the slightest hint of daylight, performing effectively during overcast days, in the shade and during low-light periods of early dawn and late dusk. Powered by the sun, Sol-A-Vent® operates noiselessly, and requires no external power source, wiring or switches.

Materials used in the design withstand wind-blown water, intense sunlight and other corrosive and abrasive conditions. The solar cell and motor are hermetically sealed to keep out moisture.

Distributed by: BEST MATERIALS LLC, Phoenix AZ
602-272-8128 800-474-7570 www.bestmaterials.com

Vents made from sturdy gauge aluminum, either primed for asphalt roof systems, PVC coated base for PVC systems or bare metal for other applications.

With no power connections Sol-A-Vent® is simply flashed to the deck like other roof vents.

Shown on the right is the solar powered fan mechanism viewed from the under-side of the vent.



FLAT ROOF APPLICATION

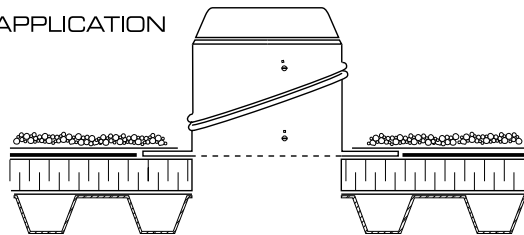

PITCHED ROOF APPLICATION

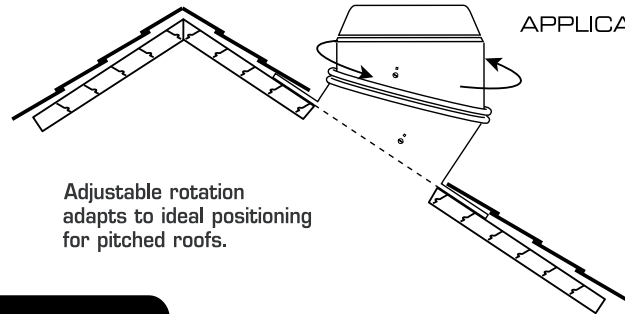

Adjustable rotation adapts to ideal positioning for pitched roofs.

INSTALLATION

Step 1: Before installing the Sol-A-Vent set the appropriate desired angle of the solar panel relative to the roof pitch by 1) turning the vent stack on its base and by 2) rotating the top section of the adjustable seam. You will likely need to loosen the 4 slotted bolts on the vent stack sides to rotate the upper panels freely on the base flange.

Step 2: For flat (horizontal) roof installation: Prepare an opening in the roof membrane and an 8" opening in the roof insulation. Install the Sol-A-Vent beneath the roof membrane but on top of the insulation. Secure with nails or screws if appropriate. Flash in the base according to standard details for the roof membrane in use.

For a steep roof installation: After step 1 prepare an 8" opening in the roof deck to access the area to be vented. Attach the vent to the deck with screws or nails and make final adjustments to the desired angle of the Sol-A-Vent panel. Re-tighten the 4 slotted bolts and then flash in the vent base appropriately.

SPECIFICATIONS

- Plain aluminum. Optional asphalt coated flange at no charge.
- Optional PVC coated base for PVC roof membrane.
- Optional chrome cap at an extra cost on aluminum vent body.

MANUFACTURER/WARRANTY

Marathon Roofing Products offers more than 30 years experience supplying the roofing industry with quality roof drains, vents, breathers and roof accessories. Products for both new and replacement roofing are adaptable to all roof systems to provide reliable and long life performance. Marathon roof drain assemblies can also be custom fabricated to meet almost any situation.

Marathon products are inspected and warranted. Any product proven to be defective within one year of installation will be replaced or cost price refunded, at the Company's option, subject to minor limitations.

MODEL	HEIGHT		STACK DIAMETER		FLANGE DIMENSIONS		WEIGHT		PKG'D. CTN.
MS-A	10"	254 mm	8"	203 mm	16" x 16"	406 x 406 mm	2 1/4 lbs.	1 kg	2