

## STEP 1

Inspect existing drain pipe to ensure there are no cracks or signs of potential failure. Using a wire brush, clean existing drain line of asphalt, loose debris and moisture. If necessary, use a heat gun to dry a wet line.

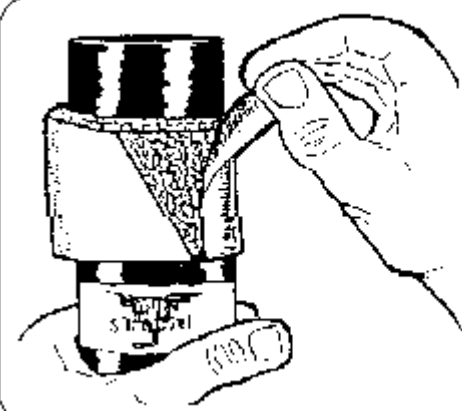

## STEP 2

Ensure drain sleeve is the proper size before removing plastic restraining tape. Remove plastic restraining tape just prior to inserting into drain sleeve. Apply a bead of water cut-off mastic to leading edge of expanding tape. Turn drain in a clockwise motion while seating drain unit. Seat entire unit so flange is flush with insulation.

NOTE: Heat and U.V. will accelerate the expansion rate of the foam tape. In colder weather a heat gun may be used to expand foam tape. In the event that the precompressed tape has expanded larger than the inside diameter of the roof drain, the tape can be recompressed by hand.

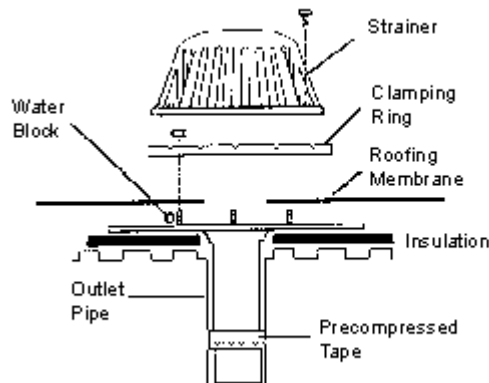

## STEP 3

Remove dome strainer and clamping ring. Per Roofing Manufacturers recommendations, apply a bead of water-block on the drain flange (water-block supplied by Roofing Manufacturer). Bring roof membrane onto drain flange. Membrane should extend past drain clamping ring to insure membrane from slipping out. Install clamping ring and tighten so the water-block and membrane compress and form a watertight gasket. Do not tighten bolt greater than 100 torque inch pounds.

With all good roofing practice, all drains should be water tested to ensure existing drain system is free to facilitate water flow. Extended insert tubes are available for excessive insulation buildup.