



Expansion Joint Covers

Technical Product Information

Straight Flange Roof-to-Roof Installation Instructions

READ COMPLETE INSTRUCTIONS CAREFULLY BEFORE STARTING

STEP 1

Verify all necessary materials are on hand

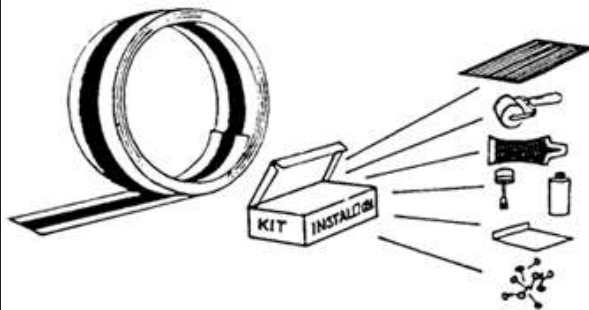

STEP 2

On both sides of expansion joint opening, install wood nailers, tapered edge strips and roofing to opening

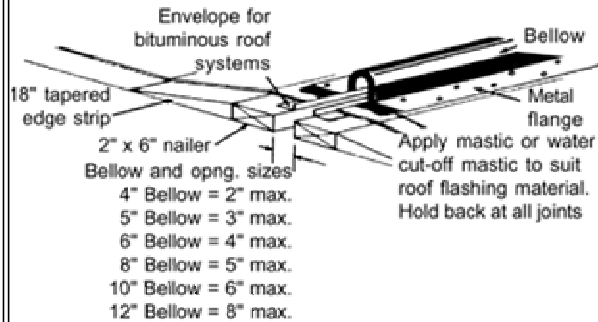

STEP 3

On both sides of opening, after roof membrane is installed, strike chalk lines as shown and apply mastic or water cut-off mastic on one side of opening where flange will rest. Hold back at all joints

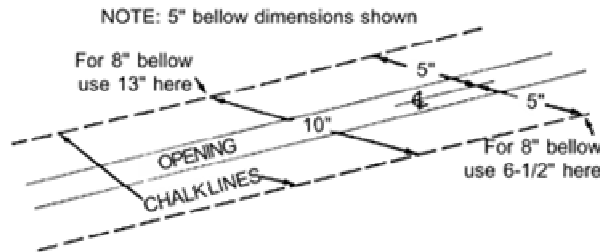

STEP 4

Install all Crossovers, Tees, and Corners first
 Trim all flanges to leave 1/2" space between each joint. BUTT BELLOWS. Hold all mastic or adhesives back at all joints.
 Then install straight runs with the same space in flanges and the same butting of bellows

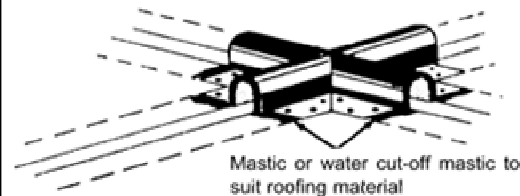

STEP 5

Unroll coil of expansion joint cover out over opening approx. 15-20 feet (foam side down) and align edge of metal with chalkline on side where mastic was applied. Nail the inside edge at intervals of 2 feet, making certain it is flat when the nails are started. Return to starting point and stagger-nail as shown below. Continue to unroll coil ahead of nailing and keep edge on chalk line.

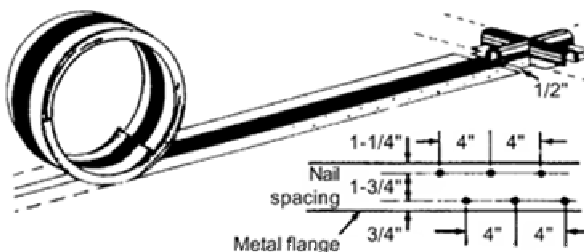

STEP 6

After one flange has been nailed, return to starting point. Turn second flange back and apply mastic or water cut-off mastic to second side of opening. Pull second flange in to chalk line for approx. 10 feet, forming bellow, as shown. Nail flange as shown in Step 5. Continue pulling this flange to chalk line several feet ahead of nailing.

NOTE: Trim all flanges to leave 1/2" space between each joint. BUTT BELLOWS. Hold all mastic or adhesives back at all joints.

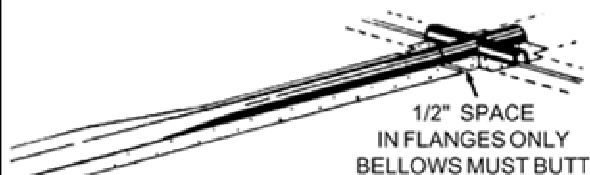

ROOF EDGE PREPARATION

On both sides of expansion joint opening, install wood nailers and tapered edge strips. Taper wood nailers and tapered edge strips down to feathered edge at eave. Install roofing as specified by roofing membrane manufacturer to edge of expansion joint opening and edge of roof.

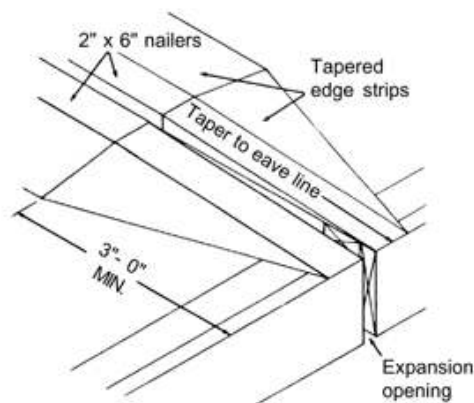

METAL EDGE TERMINATIONS

Before bending metal at edge, slit foam insulation and remove as shown

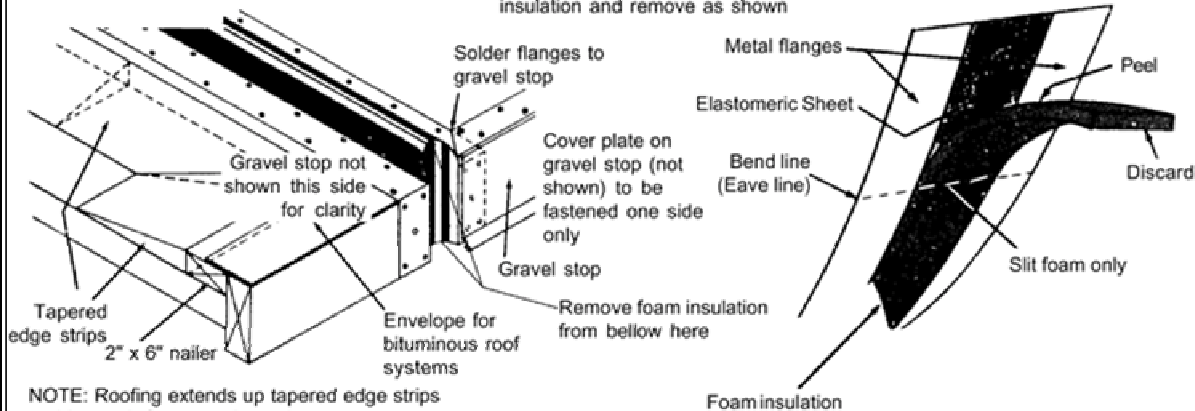

GUTTER TERMINATIONS

Expansion joint for gutter is made in the shop by removing foam from expansion joint cover and forming metal flanges to fit gutter. Solder and rivet flanges to gutter each side. Leave buckle in elastomeric sheet for gutter movement.

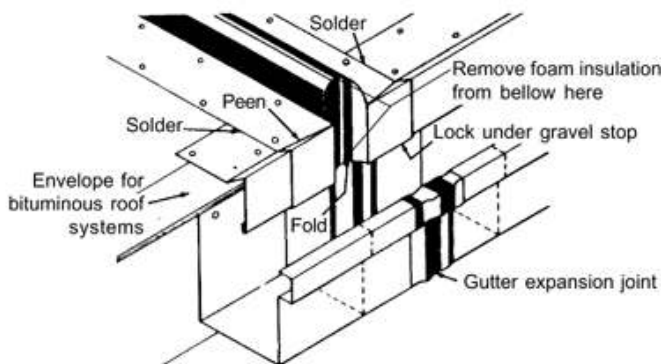

COLD WEATHER CAUTION:

For cold weather applications, make certain splice covers are warm and pliable before starting.

STEP 1

Make certain that all surfaces in area of joint are clean and dry. If necessary, clean metal flanges 4" on each side of joint with detergent or mild solvent to remove any oily film before proceeding. Use only the materials supplied with expansion joint covers for splicing.

Read directions on splicing primer can before starting. Brush splicing primer on bellows and both metal flanges, out 4" on each side of butt joint. Use only enough to cover 1 to 1-1/2 mils dry thickness. Make certain joint has been covered with primer- especially metal flanges.

STEP 2

Peel the release paper halfway from one end of the self-sealing splice cover and crease (see Detail A).

Center the splice cover over butt joint with peeled side and crease in release paper down and centered over bellows (see Detail B). Allow cover to roll into place naturally and start pressing exposed side of cover onto the bellows with wood roller provided, holding end up. Work roller toward edges to remove all air bubbles. If air bubbles occur, pull cover back and roll out again before proceeding. Use metal tool provided to force cover tightly into junction of bellows and metal flanges (see Detail C). Do not stretch cover. Hold tool in place as cover is rolled over metal flange (see Detail D).

Peel release paper from remaining half of cover and install on second side of bellows as described and illustrated above.

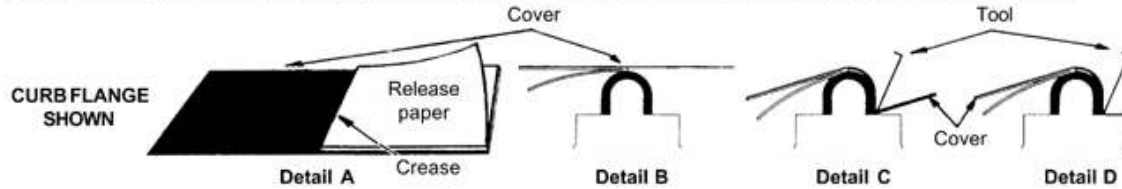
**STEP 3**

To complete the splice cover installation, apply a bead of caulking starting at the edge of the splice cover and extending out about 1" along the crimp at each of the four places where the splice cover crosses the crimp. Force as much caulking as necessary into the crimp to insure a tight seal.

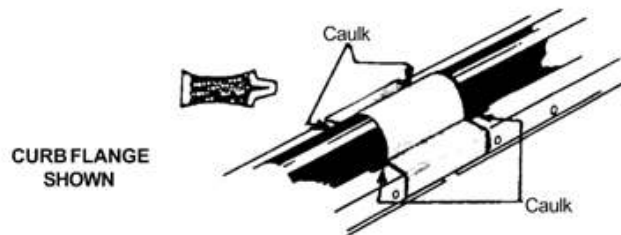
**ROOF-TO-ROOF**

Complete sealing of flanges in accordance with roofing manufacturer's specification for stripping metal flanges. Apply ballast as required by roofing manufacturer up to bellows. Do not apply any bituminous materials to bellows.

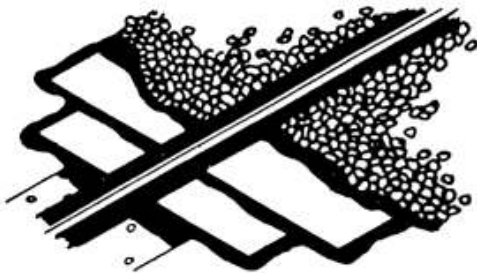

Distributed by: [BEST MATERIALS LLC](http://BESTMATERIALS.LLC)
 Ph: 1-800-474-7570, 1-602-272-8128 Fax: 1-602-272-8014
 Email: sales@bestmaterials.com www.bestmaterials.com