



ReRoof Drains

Technical Product Information

Aluminum ReRoof Drain

SPECIFICATION

Furnish and install the Portals Plus, Inc., ReRoof Drain as manufactured by Portals Plus, Inc., Bensenville, IL, at all drain openings as specified on drawings.

Drain shall consist of a molded ultraviolet stabilized polyethylene or cast aluminum dome strainer, a cast aluminum epoxy coated gravel guard and clamping ring, 15" or 18" O.D. spun Aluminum drain flange. The outlet pipe shall have a pre-compressed modified asphalt impregnated expanding foam, sealing tape, having a temperature range of -40 F to +185 F and 150% minimum elongation.

(Available in 2", 3", 4", 5" and 6").

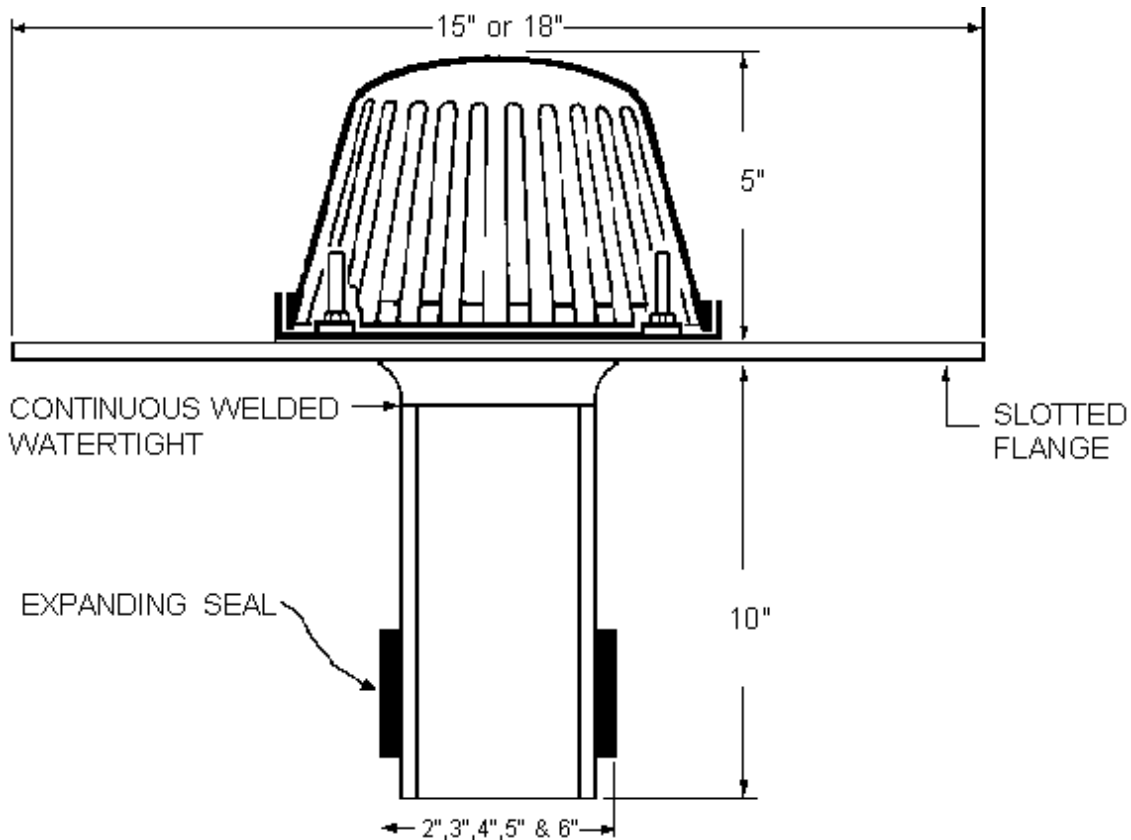

ALUMINUM REROOF DRAIN			
NEW UPC PART NUMBER	WILL FIT I.D.	DESCRIPTION	
66091	2"	ALUMINUM REROOF - w/ PLASTIC DOME	
66101		ALUMINUM REROOF - w/ ALUMINUM DOME	
66111	3"	ALUMINUM REROOF - w/ PLASTIC DOME	
66151		ALUMINUM REROOF - w/ ALUMINUM DOME	
66121		ALUMINUM REROOF - w/ PLASTIC DOME	

 <p>Standard tube length 10"</p>	66161	4"	ALUMINUM REROOF - w/ ALUMINUM DOME	
	66131 66171	5"	ALUMINUM REROOF - w/ PLASTIC DOME ALUMINUM REROOF - w/ ALUMINUM DOME	
	66141 66181	6"	ALUMINUM REROOF - w/ PLASTIC DOME ALUMINUM REROOF - w/ ALUMINUM DOME	

All information is subject to change without notice. Dimensions and specifications shown are within manufacturing tolerances.
 © Copyright Commercial Products Group of Hart & Cooley, Inc., July, 2008. All Rights Reserved.